

• 'ES25' & 'ES32' •  
**Pass-Through Dishwashers**

In-Line or Corner Feed, Wash up to 540 or 700 pieces/hour



ESTABLISHED 1932

**ESWOOD**

PROUDLY AUSTRALIAN MADE

**The professionals in integrated  
glass and dishwashing systems**

[www.goldsteineswood.com.au](http://www.goldsteineswood.com.au)

# • 'ES25' & 'ES32' Pass-Through Dishwashers •

• Built in Accordance with ANZFA and Plumbing Safety Regulations •

## Economical & Efficient Performance:

The Eswood 'ES25' and 'ES32' pass-through dishwashing machines provide excellent performance of up to 540 and 700 pieces per hour. These models will wash all types of crockery, cutlery and glassware and accept standard 500 x 500mm racks. A generous opening height of 340mm caters for bulky kitchen utensils.

## Ergonomically Designed:

Bench height pass-through operation eliminates the need for operators to bend over during loading and unloading, ensuring greater efficiency, safety and convenience.

**In-Line or Corner Feed:** 'ES25' and 'ES32' machines can be installed for in-line or corner feed, making the most of your space and working preferences. Loaded racks slide easily from an adjacent feeder bench into the wash chamber and out again after washing.

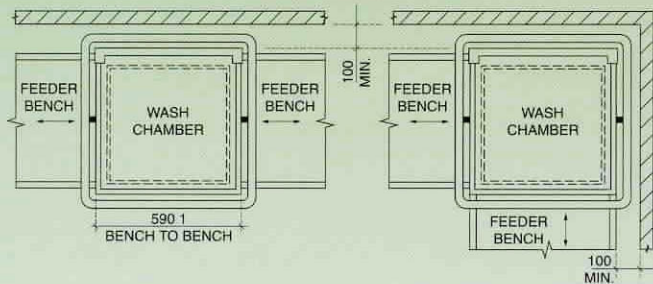

In-Line Operation

Corner Operation

**Fully Automatic Operation:** Just slide the loaded rack in, cycle starts automatically when hood is closed and stops automatically if hood is opened at any time.

**Powerful Wash System:** Powerful wash and rinse action from high volume pump and upper and lower spray arms. Independent wash and rinse systems ensure high wash quality and hygiene.

**Built-in Hot Water Booster Heaters:** Booster heaters with low water safety cut out and thermostatic control ensure correct water temperature and level is maintained for safe hygiene and continuous use. Wash and rinse tanks have convenient automatic fill.



**Quality Endorsed Company**

Head Office  
ISO9001 Lic 2900  
SAI Global

**Quality Stainless Steel Construction:** Manufactured to Eswood's high quality standards from stainless steel, non-ferrous and durable synthetic materials for reliable operation. Filter and spray arms easily removable for cleaning. Fully guaranteed and backed by our nationwide support network.

Specifications	'ES25'	'ES32'
Hourly Capacity	540 pieces	700 pieces
Wash Cycle Time	105 secs	60/70 secs
Dwell/Rinse Cycles	5/13 secs	5/13 secs
Wash Racks (500 x 500mm)	2	3
Cutlery Containers	1	2

## Wash Pump, Tank & Element

Wash Pump Motor	550 watts	615 watts
Wash Pump Capacity	310 l/min	400 l/min
Wash Tank Capacity	30 litres	
Wash Tank Heater	2400 watts	2800 watts
Water Temperature	60° – 65°C	60 – 65°C

## Rinse Tank & Element

Rinse Pump	375W	
Rinse Tank	12 litres	
Rinse Tank Heater	3100 watts	5600 watts
Water Temperature	83°C	
Water Consumption	3.5 litres per cycle	

## Electrical & Water Connections

Electrical Input (max)	240/50/1N 3.5kW	415/50/3N 9.5kW
Electrical Connection	15A lead/plug	By installer
Hot Water Input	65°C min. @ 100 to 400 kPa	
Net Weight	103kg	106kg

A. Drain 2" BSP.

B. Hot Water Supply Inlet 1/2" BSP.  
100 to 400 kPa. (15 to 56 psi).

C. Electrical Connection, C<sub>1</sub>=ES25/C<sub>2</sub>=ES32

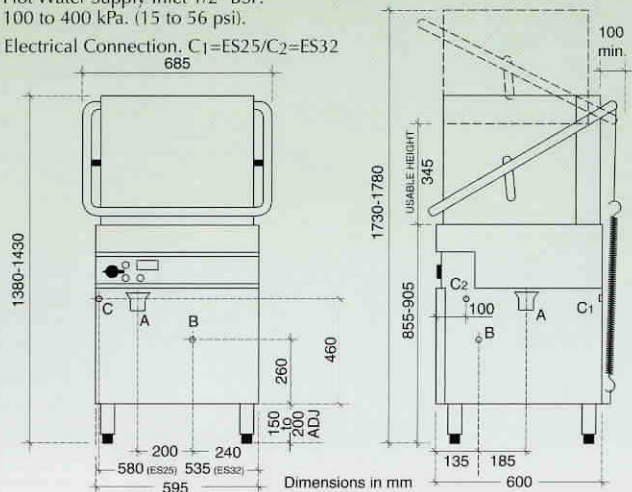

ABN 74 000 100 845 – ABN 87 002 481 521

Group Sales: 211-213 Woodpark Rd, Smithfield NSW 2164  
Telephone (02) 9604 7333 Facsimile (02) 9604 5420  
Vic (03) 9553 1355. Qld (07) 3890 1811.  
SA (08) 8238 3423. WA (08) 9456 0559.  
Distributors: ACT (02) 6280 4088. Tas (03) 6234 8300.

Proudly Distributed by

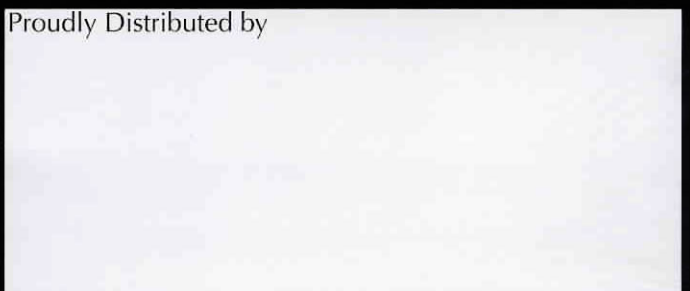

Goldstein Eswood continually strive to improve all of our products, therefore specifications may be amended from those printed in this brochure without notice. Publication ESW9131.0808